

Special features

- Voltage or current excitation
- 4 or 6 wire connection
- For up to four 350-Ω transducers
- Adjustment via DIP switches and potentiometers
- Plastic enclosure for mounting on DIN rails



Specifications

Accuracy class	0,1
Span adjustment	0,2 ... 4,5 mV/V
Zero adjustment	±10 % FSO
Excitation	
- Voltage excitation	5 / 10 VDC
- Sensor min. impedance	82 Ω
- Current excitation	10 / 20 mA
- Sensor max. impedance	400 Ω
Amplifier	
- Gain	440 ... 10000
- Input offset voltage drift	1 uV / °C
- Thermal sensitivity drift	150 ppm / °C
- Non-linearity	0,05 % FS
Active filter, 2nd order	
- max frequency range	4 kHz
- min frequency range	3 Hz
Output voltage	
- Range	± 10 V
- Min. load impedance	2 kΩ
Output current	
- Range	4...20 mA
- max. load impedance	600 Ω
Power supply	
- Range	24 VDC ±15 %
- Max. current consumption	200 mA
Temperature range	
- Operating	- 10 ... + 50 °C
- Storage	- 40 ... + 85 °C
Degree of protection	IP20

Block diagram

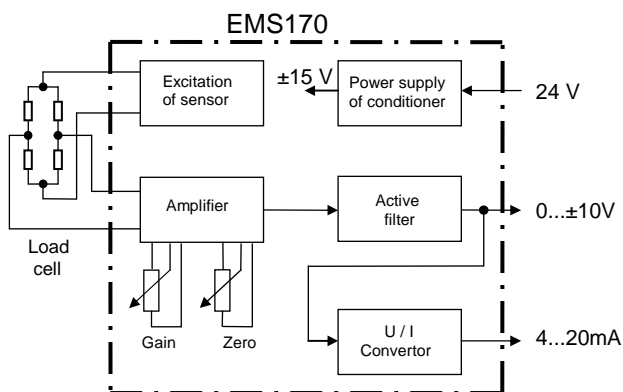

Outline Dimensions (mm)

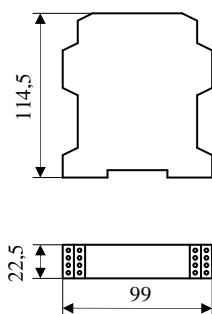

Wiring diagram, 4 – wire technique

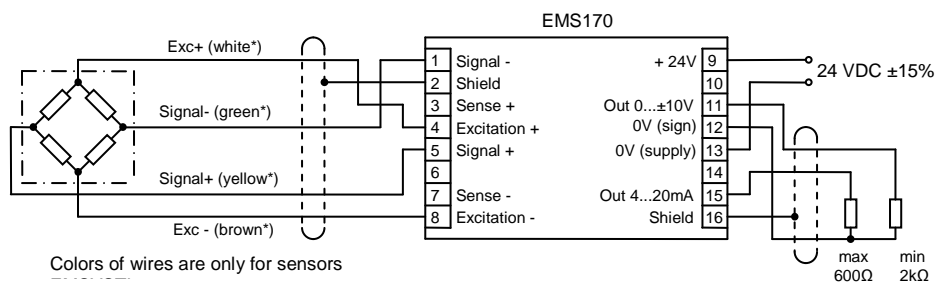

Wiring diagram, 6 – wire technique

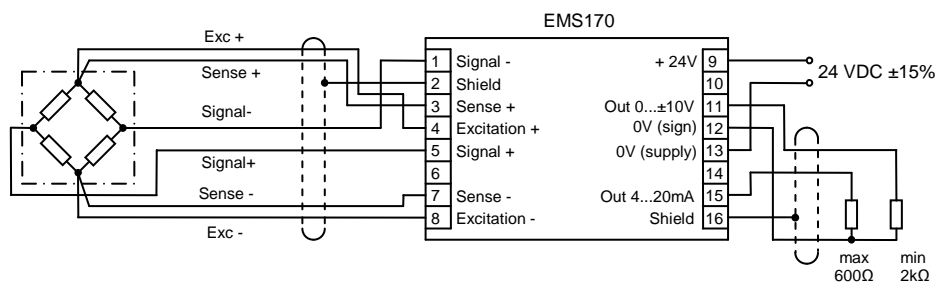

Wiring diagram, 3 load cells, 4 – wire technique

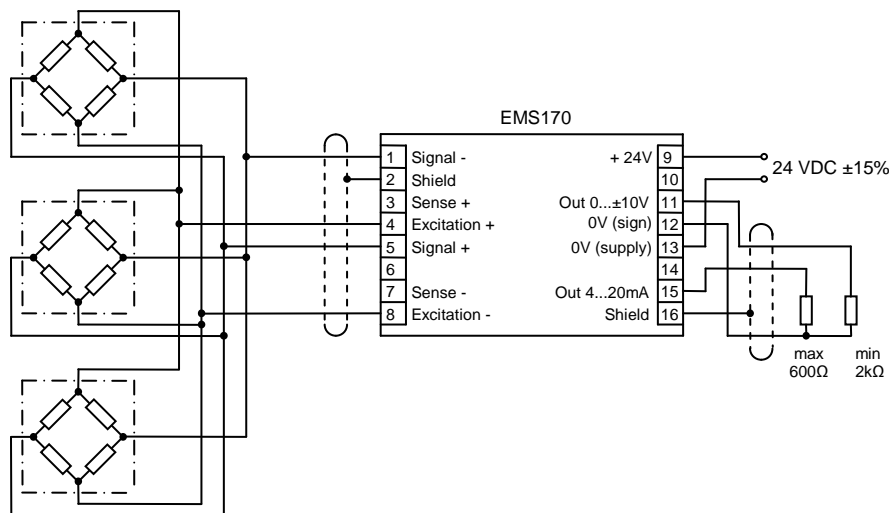

Wiring diagram, current supply of sensor

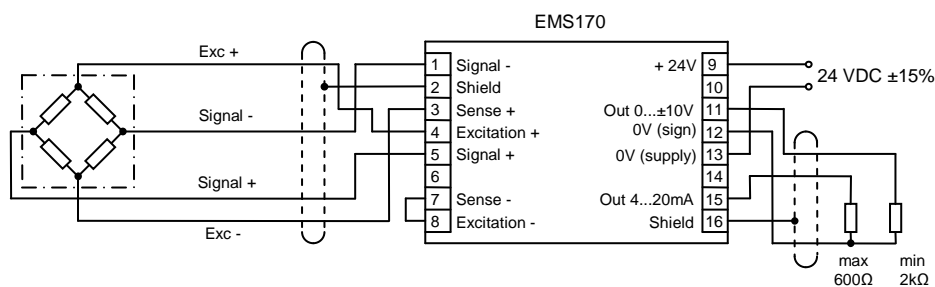

Setup

Function of DIP switch	Setup of DIP switch
S1 – 4 Excitation of load cell: - constant voltage excitation - constant current excitation	S1 – 4 = OFF S1 – 4 = ON
S1 – 1, 2, 3 Range of voltage excitation (S1 – 4 = OFF!): - bridge voltage excitation + 10 V - bridge voltage excitation + 5 V	S1 – 1 = OFF, S1 – 2 = OFF, S1 – 3 = OFF S1 – 1 = ON, S1 – 2 = OFF, S1 – 3 = ON
S1 – 1, 2, 3 Range of current excitation (S1 – 4 = ON!): - current excitation 10 mA (max resistance of load cell 1000 Ω!) - current excitation 20 mA (max resistance of load cell 375 Ω!) - current excitation 40 mA (max resistance of load cell 63 Ω!)	S1 – 1 = ON, S1 – 2 = ON, S1 – 3 = OFF S1 – 1 = ON, S1 – 2 = OFF, S1 – 3 = OFF S1 – 1 = ON, S1 – 2 = OFF, S1 – 3 = ON
S2 Sensivity of load cell adjustment: - 0,5 mV/V - 1,0 mV/V - 1,5 mV/V - 2,0 mV/V	S2 – 1 = ON, S2 – 2 = ON S2 – 1 = OFF, S2 – 2 = ON S2 – 1 = ON, S2 – 2 = OFF S2 – 1 = OFF, S2 – 2 = OFF
S3 Range of active frequency filter: - 4 Hz - 40 Hz - 400 Hz	S3 – 1 = OFF, S3 – 2 = OFF, S3 – 3 = ON, S3 – 4 = ON S3 – 1 = ON, S3 – 2 = ON, S3 – 3 = OFF, S3 – 4 = OFF S3 – 1 = ON, S3 – 2 = ON, S3 – 3 = ON, S3 – 4 = ON

DIP switch position diagram

